

Vman®



VMAN GENERATOR SET GSV-V-450/550@50HZ

One stop power solution supplier

WHO WE ARE

Established in 2007, VMAN ENGINE is an “all in one” power generation solutions provider based in China.

We start our business of G-Drive engine range from 62kW to 1000kW, as a professional engine maker, we import modern technology and established our own engine brand “VMAN”.

We export diesel engine over more than 42 countries, we specialize in the manufacturing and servicing of generators, fully custom-designed generator sets are offered to meet

clients’ diverse requirements and stringent international specifications.

Headquartered in Shanghai, China, VMAN Engine capitalizes on our founders’ 15 years of experience and expertise in the power generation industry.

We set our new branch Company in Singapore as our Asia-pacific region.

We are partners with renowned brands and are growing in local and international markets.

STRONG VALUES & FUTURE FORWARD VISIONS

We attribute our success to a combination of factors: premium products, personalized and highly responsive services as well as our dedication to offering the best to clients. With our firmly held-values to guide our business and brand, we believe that we can achieve even greater success in years to come.

Reliability: We ensure products and services are delivered to meet high standards of quality within a solid timeframe.

Integrity: We believe that trustworthiness and open communication are the key to building excellent partnerships with clients. We are dedicated to constantly improving ourselves and thus give the best to our customers.

Responsiveness: Clients are always prioritized. We make sure that every enquiry and issue are resolved as efficiently as possible through proactive solutions, personalized services and fast response time.

Independence: We strive towards being the best total power solutions providers in the country, capitalizing on our practical and autonomous business approach as well as our in-depth knowledge of local industries.

HISTORY

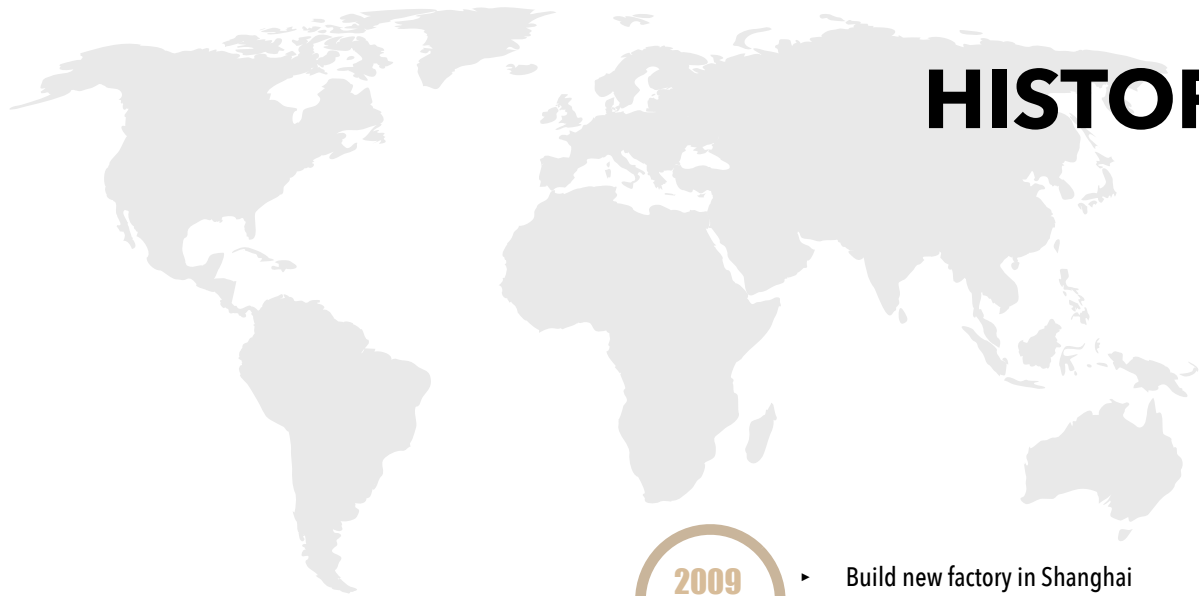

2007-2008

▶ **Importing technology & Drawing interpretation**
Part drawing, assemble drawing, machine drawing, QA system, etc

2008-2009

▶ **Learning & Training**
5 times staff training abroad
4 times professor to our factory for guidance

From 2009

▶ **CKD & CBU Diesel engines**
Getting aptitude of assembling CKD diesel engine, Match up CBU&CKD diesel engines with Customers

2009-2014

▶ **Build new factory in Shanghai**
Realize home manufacture and finish all series of V6 V8 V12 V16 engine and get excellent feedback of customers

From 2015

▶ **Starting international trading business**
Now had export Korea, Taiwan, Indonesia, Algeria, Russia, Pakistan, Malaysia, UAE, Vietnam, Poland, Albania, Argentina and other countries.

2019-2021

▶ **Building New Branch factory**
In ChangZhou City, Extend more power range products C series and CE series, power range from 62kW to 1000kW.



New branch factory in ChangZhou City

BESPOKE PRODUCTS & SOLUTIONS

VMAN company offers reliable, innovative and quality power generation sets and solutions to meet specific requirements of our clients' projects

GENERATOR/ALTERNATOR

Advanced self-exciting, self-regulating brushless dependable life. Features include fully interconnected damper windings, cooling systems, sealed bearings, Class H insulation and 2/3 pitch with THF<2% and TIF<50.

CONTROL PANELS

Standard control panel is fully equipped with all necessary engine gauges, AC meters and warnings.

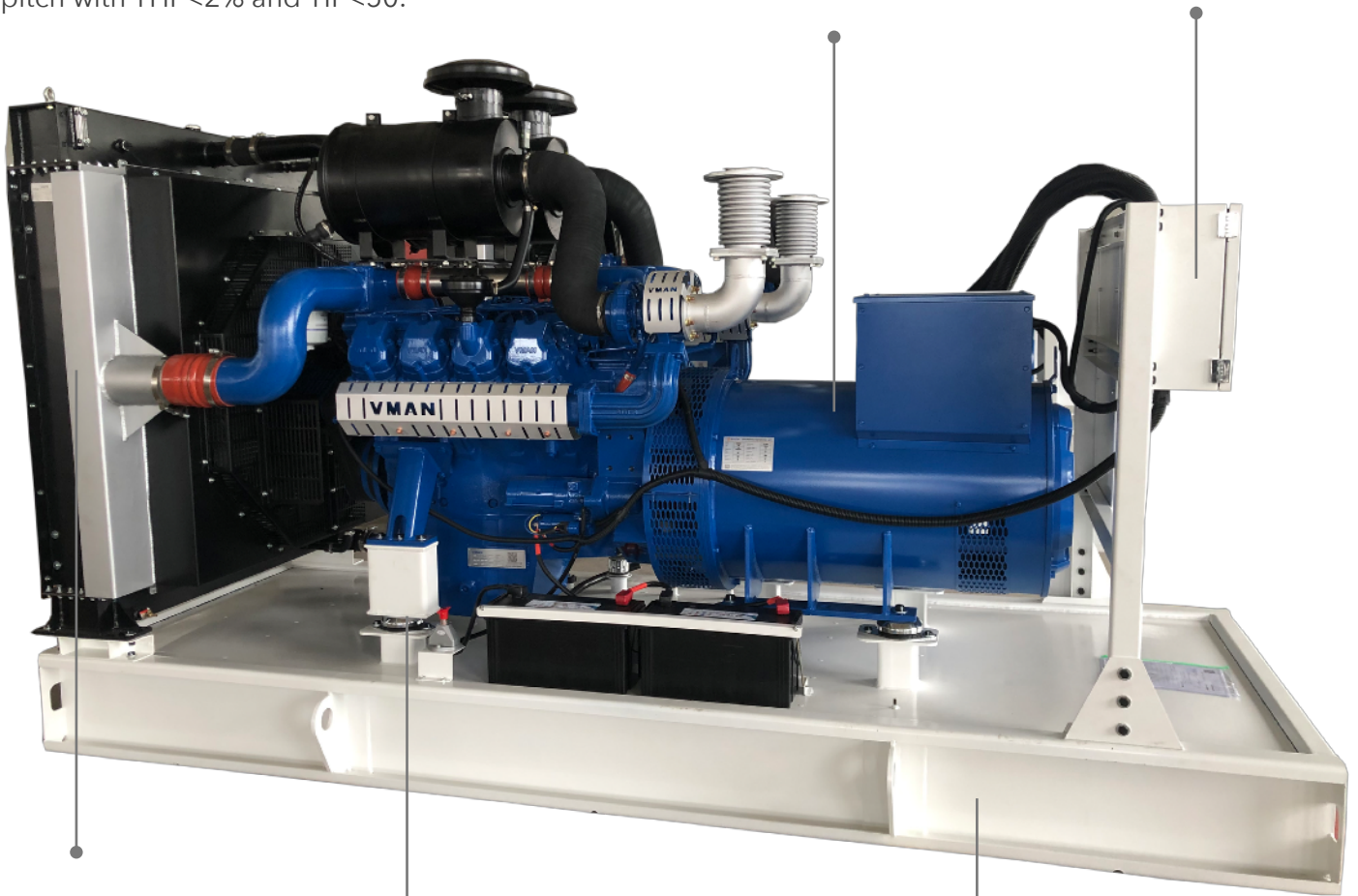

Cooling systems, designed to optimize power up to 50 ambient temperature

VIBRATION ISOLATORS
Rubber pad anti-vibration mountings isolate tank base skid from engine / Alternator assembly

TANK BASE
Tank base incorporates enhanced lifting and mounting points.

VMAN company offers reliable,
innovative and quality power
generation sets and solutions to meet
specific requirements of our clients'
projects

COMPACT SERIES

GENERATOR POWER RANGE : 25 KVA - 275 KVA

CELEBRITY SERIES

GENERATOR POWER RANGE : 325 KVA - 455 KVA

VICTORY SERIES

GENERATOR POWER RANGE : 410 KVA - 1000 KVA

Specification and options

		Compact Series	Celebrity series	Victory Series
Engine	4-stroke water cooled diesel engine	•	•	•
	Mechanical governor	▼	X	▼
	Electronic governor	•	X	•
	ECU controller	X	•	X
	Air intake heater or glow plug	▼	•	▼
	Manual lub Fuel drain pump	▼	▼	▼
	Coolant drain extended to edge of baseframe	▼	▼	▼
	Standard air filter	•	•	•
	Medium duty air filter	▼	▼	▼
	Fuel filter and water separator	•	•	•
	Exhaust manifold guard	•	•	•
	Coolant heater	▼	▼	▼
	Automatic lub oil refill system	▼	▼	▼
	Radiator	Engine driven radiator	•	•
Fan guards		•	•	•
Coolant drain valve		•	•	•
Alternator	Single bearing alternator	•	•	•
	Class H insulation system and Class H temperature rise (LV)	•	•	•
	IP23 Protection	•	•	•
	Automatic Voltage regular with 0.5% voltage regulation	•	•	•
	Anti condensation heater	▼	▼	▼
	Quardrature droop kit	▼	▼	▼
	Air inlet filter	▼	▼	▼
	Thermistor probes and control box	▼	▼	▼
General	Powder coated farbricated steel baseframe	•	•	•
	Built in anti-vibration mountings	•	•	•
	Crane and fork lifting points depending on model	•	•	•
	Operation and maintenance manual	•	•	•
	Output 3 pole circuit breaker	•	•	•
	Test report	•	•	•
	Control Panel	•	•	•
Exhaust	Industrial 15dBa reduction silencer supplied loose	•	•	•
	Residential 24dBa reduction silencer supplied loose	▼	▼	▼
	Critical 35dBa reduction silencer supplied loose	▼	▼	▼
	Flexible bellows supplied loose	•	•	•
	Set on connection flangers for silencer/bellows	•	•	•
Starting	24VDC electric starter motor	•	•	•
	Battery charging alternator	•	•	•
	Engine starting battery with cables and battery tray	•	•	•
	Wet type batteries instead of dry (not available with sea freight)	▼	▼	▼
Fuel	Integral single skin fuel tank within baseframe	•	•	•
	Flexible fuel feed and return lines	•	•	•
	Low fuel level sensor	▼	▼	▼
	Fuel level meter	▼	▼	▼

- Standard Equipment ▼ Available as an option X Not available
- Fuel tank as option when generator power above 500kW

GSV-V-450/550@50Hz



Genset Model	Frequency/RPM	Genset Power	
		Standby (kVA)	Prime (kVA)
GSV-V-450 F	50Hz/1500RPM	450	413
GSV-V-550 F		550	500

General Characteristics

Model	GSV-V-450 F	GSV-V-550 F
Engine	D15A1	D15
Alternator	VA450-H or TAL-A473-A	VA500-H or TAL-A473-C
Speed Control Type	GAC 5500E	
Phase	3	
System Voltage	24	
Frequency	50Hz	
Engine Sped (RPM)	1500rpm	
Controller Model	ComAp AMF20 or DEEPEA DSE6020	
Fuel Consumption at rated condition	89	113
Noise Of Open Type (LP7m)		
Noise Of Silent Type (LP7m)	<75 dB(A) @7mt	
Dimension Of Open Type (L x W x H)	3400mm x 1410mm x 1929mm	
Net Weigh Of Open Type	3385kg	
Dimension Of Silent Type (L x W x H)	3808mm x 1552mm x 2132mm	
Net Weigh Of Silent Type	4150kg	
Fuel Tank Capacity	785L	

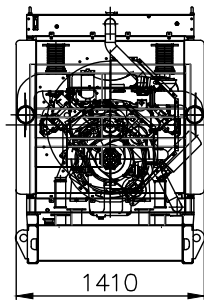
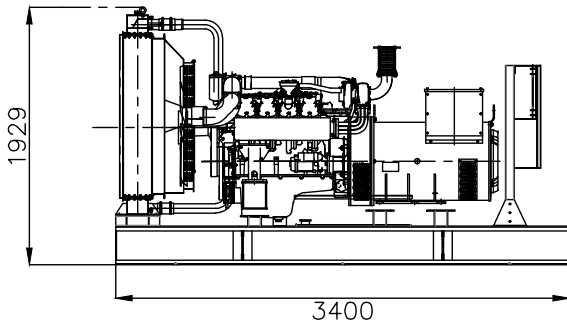
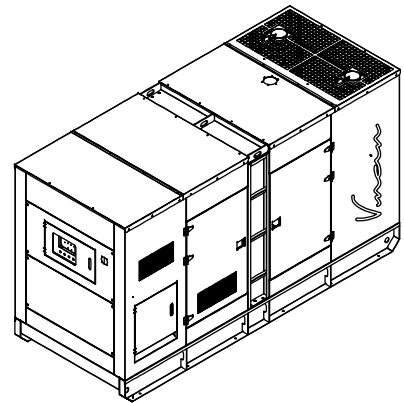
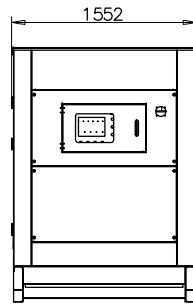
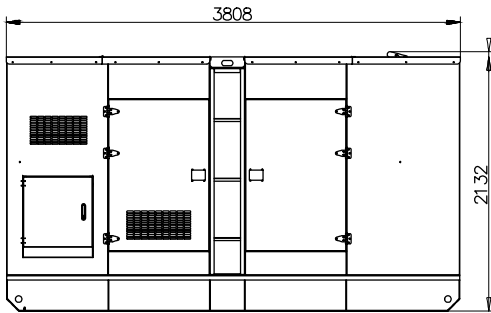

- ◆ Drawings just for reference , specific drawing for different type please contact with us.
- ◆ Info@vman-engine.com

Engine Specification

Engine Model	D15A1	D15
Engine Type	4-Cycle, V-type, 8-Cylinder, Turbo charged & inter-cooled (air to air)	
Prime power (kW/Ps)	365/496	450/612
Standby power (kW/Ps)	415/565	500/680
Continuous power (kW/Ps)	277/376	346/470
Speed	1500 rpm	1500rpm
Compression ratio	15.5 :1	14.6 :1
Displacement	14.618 L	
Bore x stroke	128 x 142 mm	
Piston speed	7.1 m/s	
Combustion Air Consumption (m ³ /h)	2418	3047
Max.Exhaust Temp.(After Turbo°C)	493	520
Exhaust Gas Flow (m ³ /h)	5709	7447
Injection timing	18°±1° BTDC @ 1500 rpm	
Dry weight {W/O cooling system}	1050kg	
Dimension {L x W x H}	1481x1389x1288 mm	
Flywheel housing	SAE 1 #	
Flywheel	14	
Number of teeth on flywheel	160	
Fuel Consumption - 110% load (l/h)	102.0	127.0
- 100% load (l/h)	89.0	113.0
- 75% load (l/h)	65.0	84.0
- 50% load (l/h)	46.0	57.0

Model		GSV-V-450 F	GSV-V-550 S
Cooling System	Coolant capacity	75L	
	Thermostat Open Temperature	71 °C start open; 85 °C full open	
	Max.Permissible Temperature	90 °C	
	Max.Coolant Shutdown Temperature	105 °C	
Fuel System	Governor	GAC 5500E	
	Maximum fuel inlet restriction	30 kPa	
	Maximum fuel return restriction	60 kPa	
	Fuel pump opening pressure	28 MPa	
Lubricating System	Low idle (kPA)	160	
	Rate speed (kPA)	200	
	Max.oil temperature permitted in oil pan (°C)	110 °C	
	Lubrication system Min.capacity (L)	27L	
Exhaust	Max.Back Pressure (kPA)	<10	
Electrical System	Starter (V)	24	
	Charging Alternator Capacity (A)	45	

Alternator Specification

Brand	Vman or Leroy-Somer
Poles	4
Connection Type	Series Star
Insulation	Class"H"
Enclosure (according ICE-34-5)	IP23
Exciter system	Self-excited, brushless
Voltage regulator	A.V.R (Electronic)
Bracket type	Single bearing
Coupling system	Flexible disc
Coating Type	Standard (Vacuum impregnation)
Frequency regulation (%)	≤±0.5
Frequency fluctuation rate (%)	≤±0.5
Voltage regulation (%)	≤±0.5
Voltage fluctuation rate (%)	≤±0.5

Configuration:

Radiator	50°C Aluminum
Base frame	Base Frame, Anti-vibration
Start Battery	Dry Charged Battery, Connection cables
Installation Accessories	Bellow, Elbow and flange, Exhaust Silencer, etc.
Tool	VMAN
Documents	Electric drawing, operation & maintenance manual, Certification, etc.

Engine:

Jacket Water Preheater
Oil Preheater

Generator Sets:

Tools with the machine

Fuel System:

Low fuel level alarm
Automatic fuel feeding system
Fuel T-valves

Control Panel:

Remote control panel
ATS
Remote controller
Synchronizing controller

Alternator:

Winding temperature measuring instrument
Alternator Preheater
Anti-damp and anti-corrosion treatment
Anti-condensation heater

Canopy:

Rental type canopy
Trailer

Exhaust System:

Protection board from heat

Cooling System:

Front heat protection
Coolant (- 30°C)

Lubricating System:

With machine oil

- Available for voltages 400/230V, 480/277V, 380/220V, 440/254V, 415/240V,220/127V, 208/120V
- All data based on ISO 3046, altitude 100m (328ft), barometric pressure 100kPa (29.53inHg), air temperature 25°C(77°F), relative humidity 30%.
- Please contact with VMAN engineer for correct generator capacity selection when the load application can't meet with the standard reference.
- VMAN diesel generators comply with standards:ISO8528 ,ISO14000 ,ISO3046, GB755,BS5000,VDE0530,IEC34-1

COMPREHENSIVE FACILITIES

VMAN engine is fully equipped with manufacturing, testing, and monitoring facilities to bring clients the best quality products and solutions.



Manufactory

VMAN engine with strong stock supply one-stop total power solution for customer, all manufacturing processes including generator sets assembly and fabrication, load testing and remote monitory are carried out on-site at our factory's facilities.

Workshop Facilities

Within the factory, VMAN Engine as a engine manufactory has a fully facilitated workshop to perform fabrication and assembly of generator sets. And also with sufficient spare parts stock to deal with any emergency.

Load testing

VMAN engine has a dedicated testing bay at our factory to offer the best testing facility. Each generator set will be proceeding multi-level testing according to the customer's standard, and also proceeding 110% load testing, sudden loading and unloading testing to ensure our generator set's quality.

INTEGRATED SERVICES

From start to finish, VMAN engine offers clients complete lifecycle generation solutions and services customized to their needs and preferences.



Our R & D Engineering is working day and night to improve the product and to make it more user-friendly. Our Installation Engineers stand with you on your site to ensure proper installation.





VMAN GENERATOR SET

VMAN ENGINE

Head office: Building102-202, Zone E10, Bay Valley II,
No.1566 Guoquan Rd(N), Shanghai 200438

Singapore office: 50 Raffles Place, #34-04 Singapore Land
Tower 048623 Singapore

Tel: +86 (21) 65186706

Fax: +86(21) 65187011

info@vman-engine.com

www.vman-engine.com

Vman[®]